



Automated reasoning in large structured theories

(Project Proposal with Alan Bundy and Roy MacCasland).

Serge Autexier

`serge@ags.uni-sb.de`

DFKI GmbH & CS Department, Saarland University, Saarbrücken, Germany

CIAO'06, April 6/7, 2006

Braunshausen, Germany

Motivation

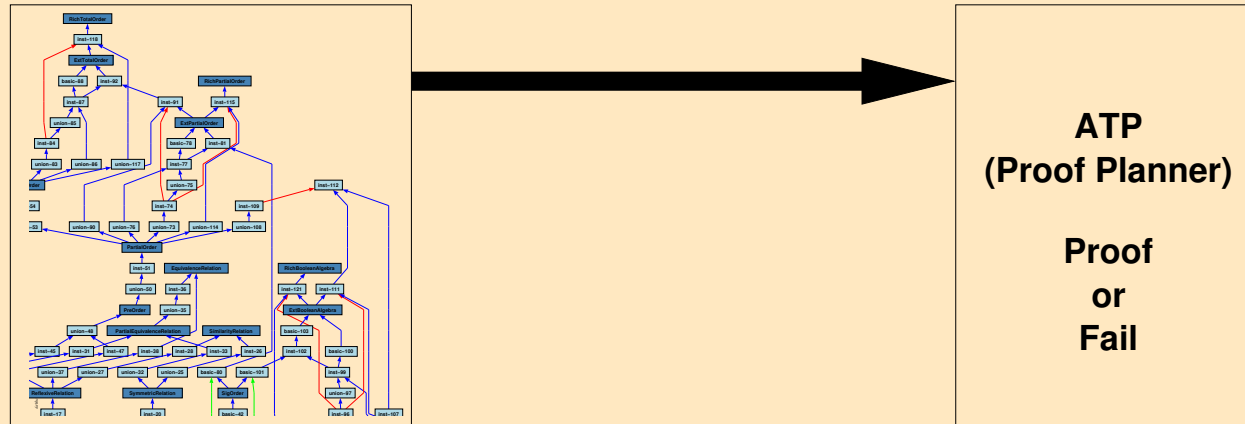

Kinds of proof search procedures, of failure and reasons:

- Complete search procedures (e.g. classical ATP)
 - ▶ Too much knowledge/Search space too large (Restrict Knowledge)
 - ▶ Not a theorem
 - Only part of knowledge has been provided: (Adjust provided knowledge)
 - All knowledge has been provided: (Definitely not a theorem)

Motivation

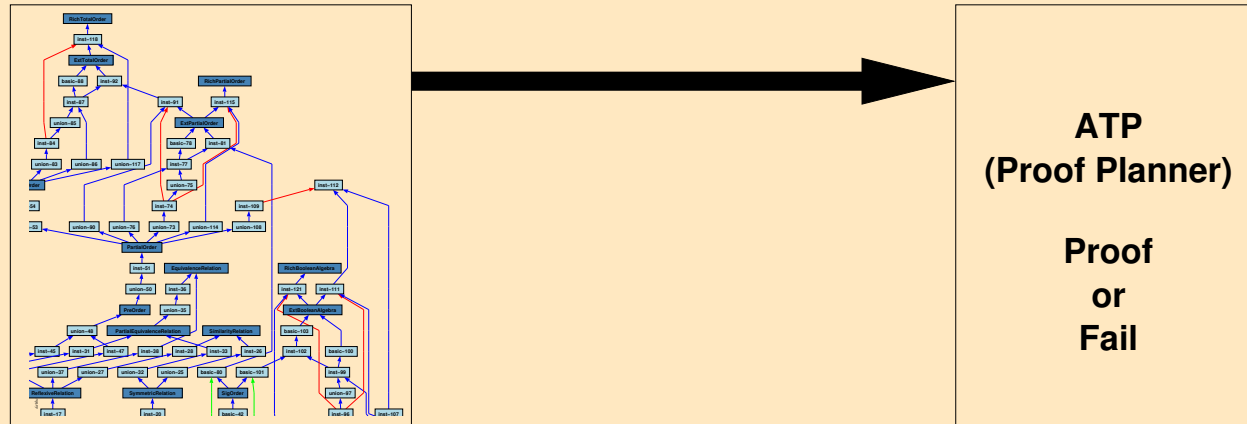

Kinds of proof search procedures, of failure and reasons:

- Incomplete search procedures (e.g. proof planner)
 - ▶ Too much knowledge: (Restrict Knowledge)
 - ▶ Not a theorem:
 - Only part of knowledge has been provided: (Adjust provided knowledge)
 - All knowledge has been provided (Definitely not a theorem)

Question

- How to automate **restriction** and **adjustment** of knowledge provided to the ATPs?
(Based on Feedback provided in case of failure)

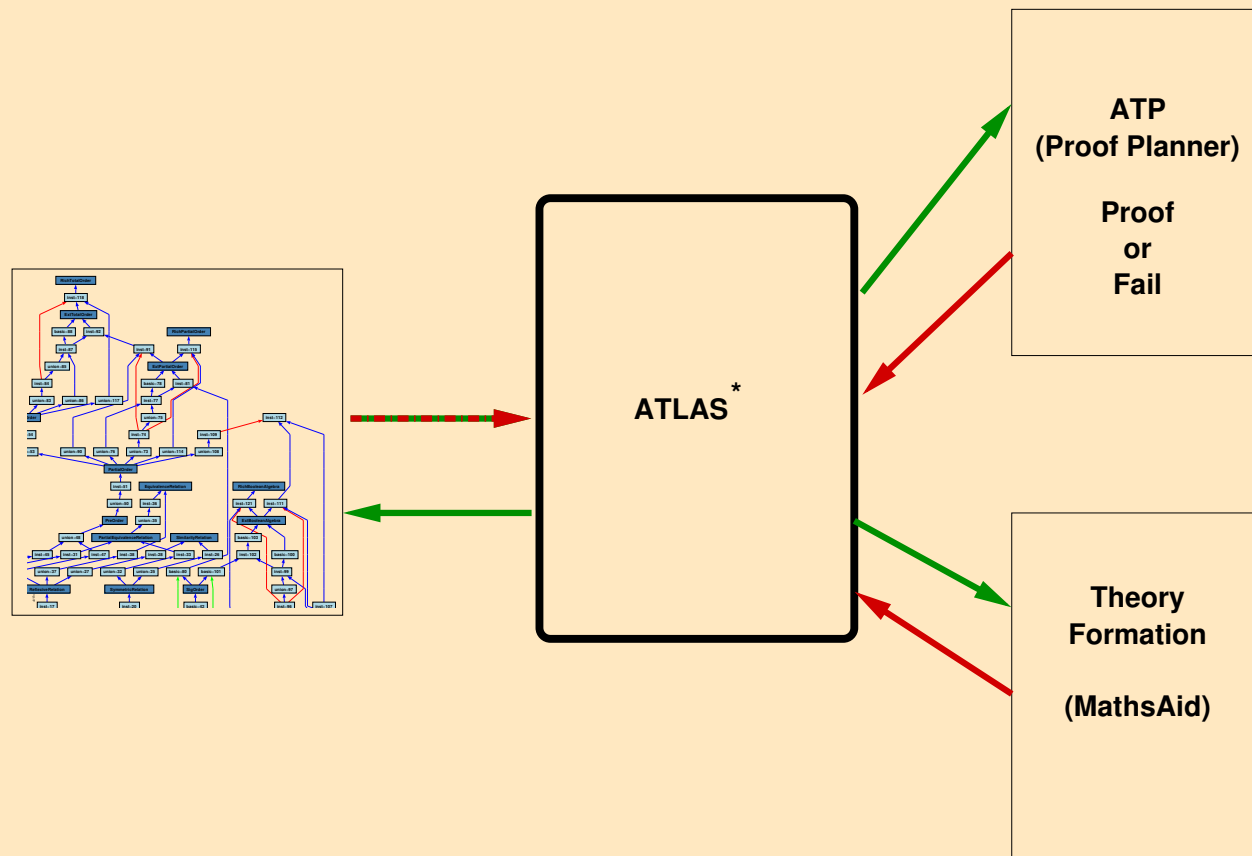

* The titan in the Greek mythology punished by Zeus by giving him the task to hold up the sky

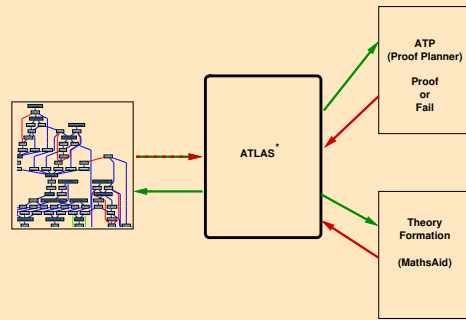

Interaction with mathematical theories:

- Criteria to characterise subsets of available knowledge?

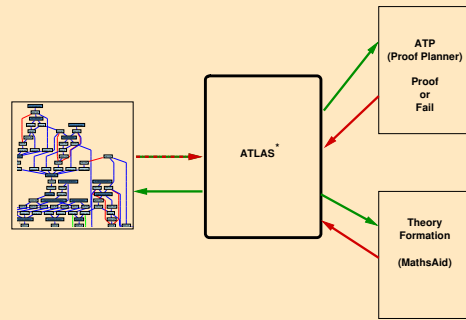

Interaction with mathematical theories:

- Criteria to characterise subsets of available knowledge?
- Depending on ATP failure analysis

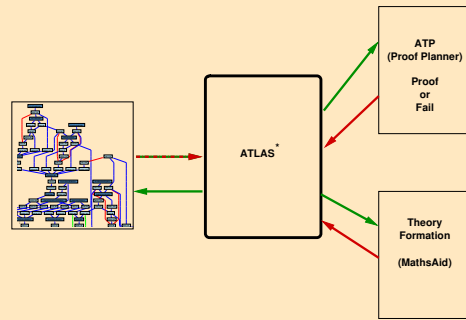

Interaction with mathematical theories:

- Criteria to characterise subsets of available knowledge?
- Depending on ATP failure analysis
 - ▶ select possibly useful knowledge

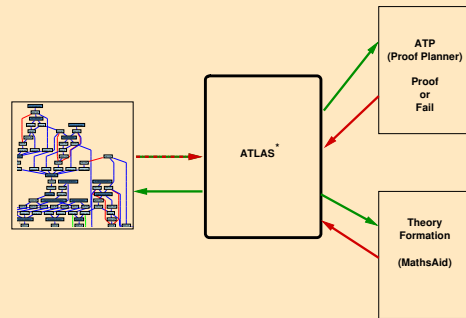

Interaction with mathematical theories:

- Criteria to characterise subsets of available knowledge?
- Depending on ATP failure analysis
 - ▶ select possibly useful knowledge
 - ▶ deselect probably useless knowledge

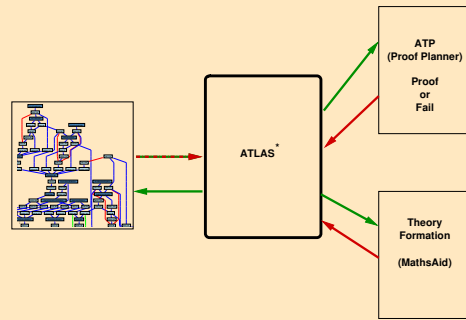

Interaction with mathematical theories:

- Criteria to characterise subsets of available knowledge?
- Depending on ATP failure analysis
 - ▶ select possibly useful knowledge
 - ▶ deselect probably useless knowledge
- If selection query fails, use theory formation to try to derive missing knowledge

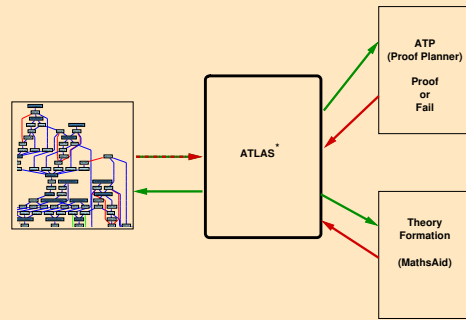

Interaction with mathematical theories:

- Criteria to characterise subsets of available knowledge?
- Depending on ATP failure analysis
 - ▶ select possibly useful knowledge
 - ▶ deselect probably useless knowledge
- If selection query fails, use theory formation to try to derive missing knowledge

Interaction with theory formation tool:

- How to select knowledge for Theory formation?

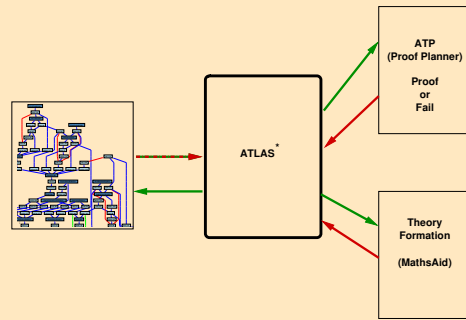

Interaction with mathematical theories:

- Criteria to characterise subsets of available knowledge?
- Depending on ATP failure analysis
 - ▶ select possibly useful knowledge
 - ▶ deselect probably useless knowledge
- If selection query fails, use theory formation to try to derive missing knowledge

Interaction with theory formation tool:

- How to select knowledge for Theory formation?
- Success criteria for theory formation?
 - ▶ Found knowledge of required type?

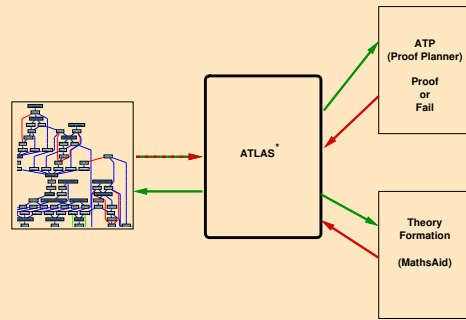

Interaction with mathematical theories:

- Criteria to characterise subsets of available knowledge?
- Depending on ATP failure analysis
 - ▶ select possibly useful knowledge
 - ▶ deselect probably useless knowledge
- If selection query fails, use theory formation to try to derive missing knowledge

Interaction with theory formation tool:

- How to select knowledge for Theory formation?
- Success criteria for theory formation?
 - ▶ Found knowledge of required type?
- “Theory formation failure analysis”
 - ▶ Adjust knowledge provided to theory formation (TF)

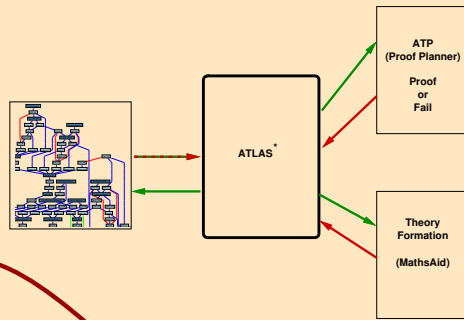

Interaction with mathematical theories:

- Criteria to characterise subsets of available knowledge?
- Depending on **TF** failure analysis
 - ▶ select possibly useful knowledge
 - ▶ deselect probably useless knowledge
- If selection query fails, use theory formation to try to derive missing knowledge

Interaction with theory formation tool:

- How to select knowledge for Theory formation?
- Success criteria for theory formation?
 - ▶ Found knowledge of required type?
- “Theory formation failure analysis”
 - ▶ Adjust knowledge provided to theory formation (TF)

Workpackages



- Part 1: Tool Environments for Investigations:
 - ▶ Integrate *IsaPlanner* (ATP) and *Mathsaid* (TF) into Ω MEGA via development graph manager *MAYA* Roy, Lucas
 - ▶ Select problem domains to conduct investigations
- Part 2: Criteria for Filtering Assertions
 - ▶ Criteria to filter assertions for ATPS and for TF
 - ▶ Strategies to adapt filter depending on results obtained from failure analysis Moa, Andrew
- Part 3: In-the-Large Reasoning Procedures
 - ▶ Implement automated in-the-large reasoning procedures + Evaluation
 - ▶ Framework to define filters and design in-the-large reasoning procedures? Volker, Manfred (Birmingham)

Summary of Main Objectives



- System environment that supports the definition and evaluation of knowledge filters and in-the-large reasoning procedures.
- Criteria characterising the knowledge that can be provided by ATP, ATF and systems maintaining structured theories
- Basic set of filters to formulate queries for each subsystems
- Criteria to rate the response given by a subsystem to a query.
- Sample in-the-large reasoning heuristics:
 - ▶ Given the goal to prove a conjecture
 - ▶ Automate cooperation among the subsystems by formulating queries, evaluating responses and formulating new queries.