

System Architecture for using Location Information for Process Optimization within a Factory of Things

Dipl.-Ing. Peter Stephan

Organisation TU/pak – DFKI/IFS – SmartFactory^{KL}

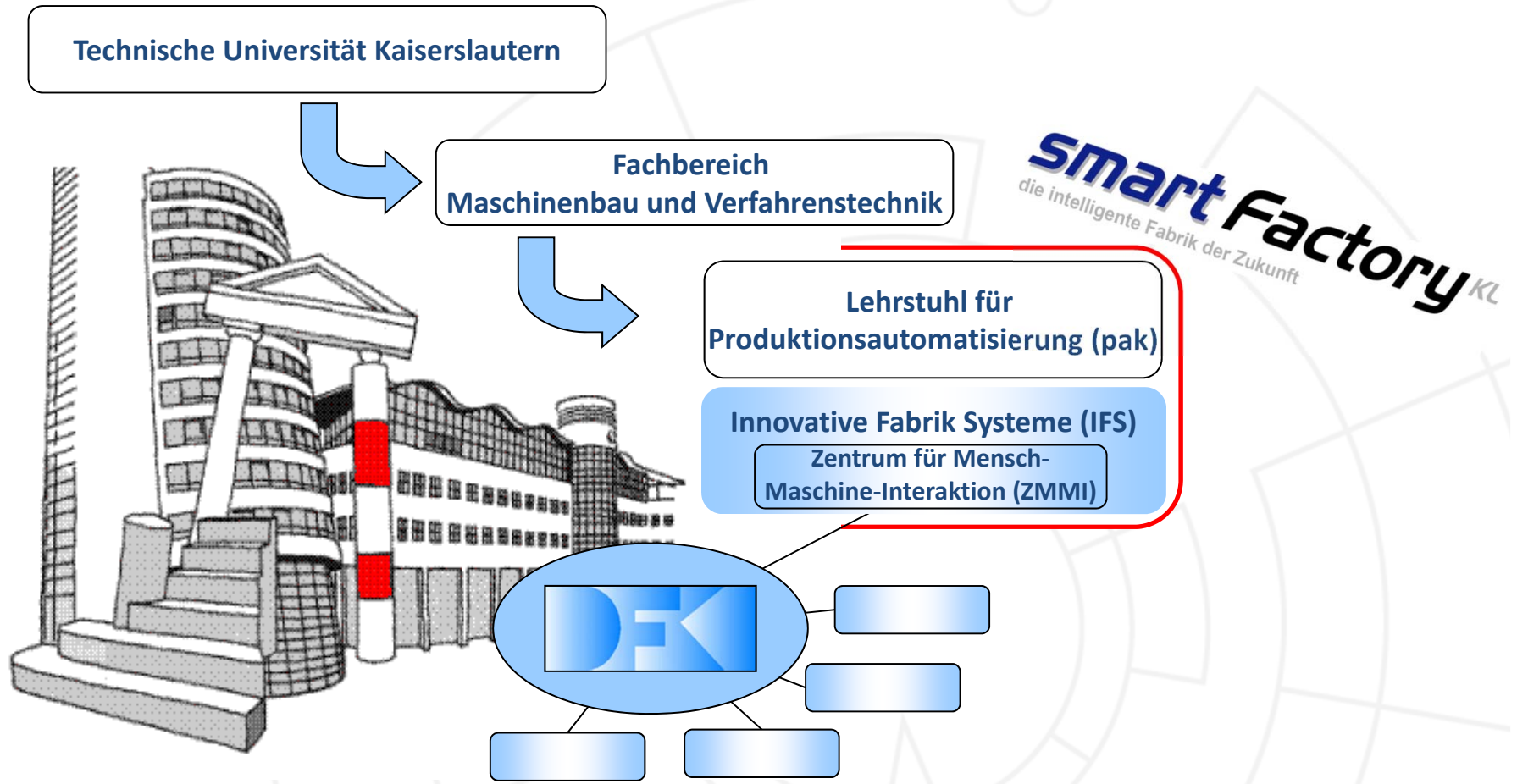

Starke Partner bilden die *SmartFactory*^{KL}

- Erstes herstellerunabhängiges Forschungs-, Entwicklungs- und Demonstrationszentrum in Europa / wahrscheinlich auch weltweit
- Ziel: Integration ausgereifter Informations-Technologien in die Fabrikautomation

Mitglieder:



Sponsoren:



smartFactory^{KL}

Agenda

Elevating location-aware applications in the domain of industrial production to the next level through architectural support.



Motivation

The Internet of Things is shaping future factories



Use Case

Using location information for factory maintenance support

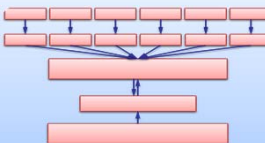

Architectural Approach

Data Representation and Interpretation



Pro's and Con's for the Architecture

Hardcoded vs. semantic solution

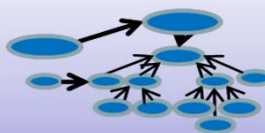

Outlook

Performance Testing, Ontology Extension

Today's Factory Environment

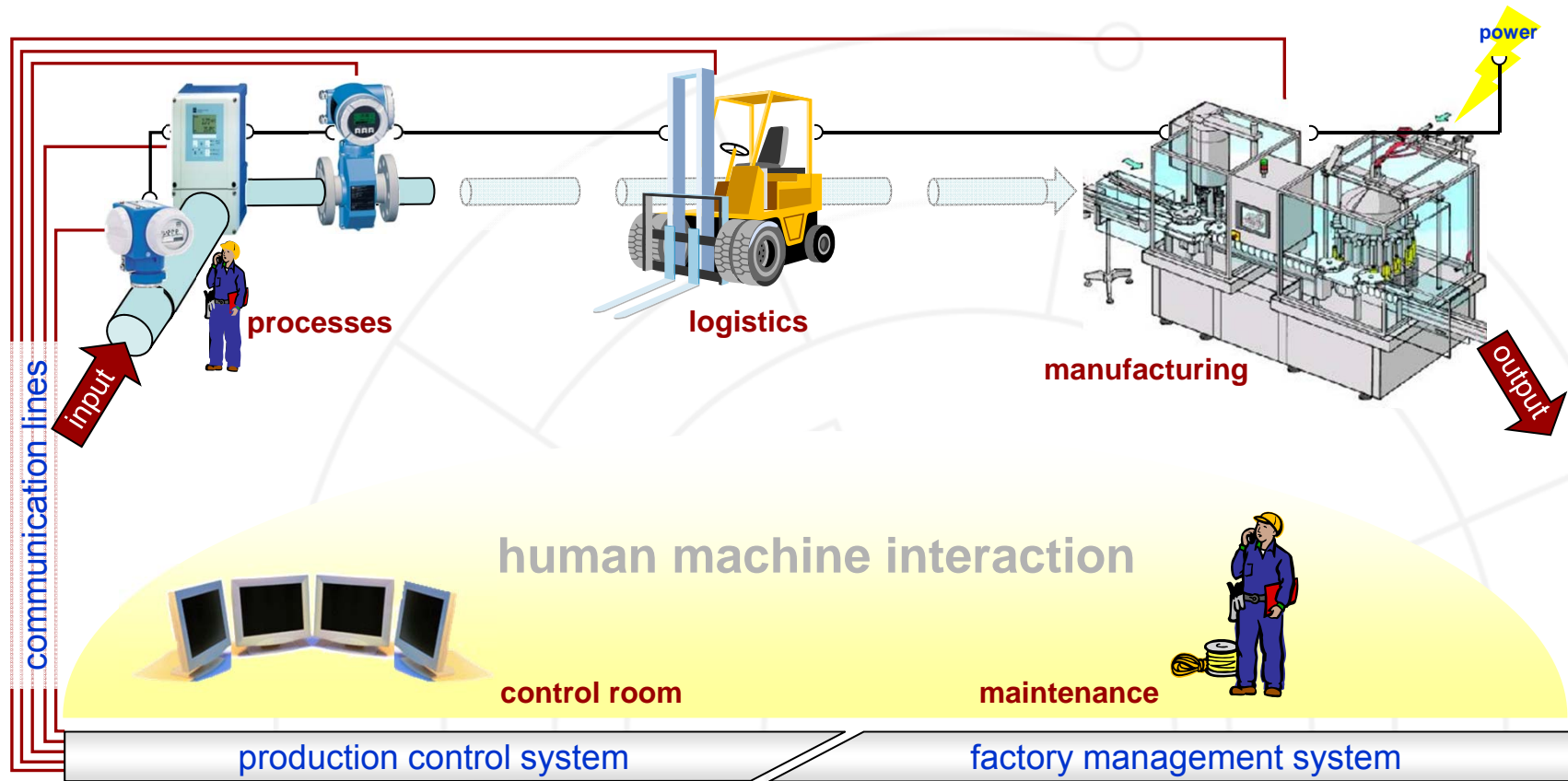

The agile and versatile, factory of the future

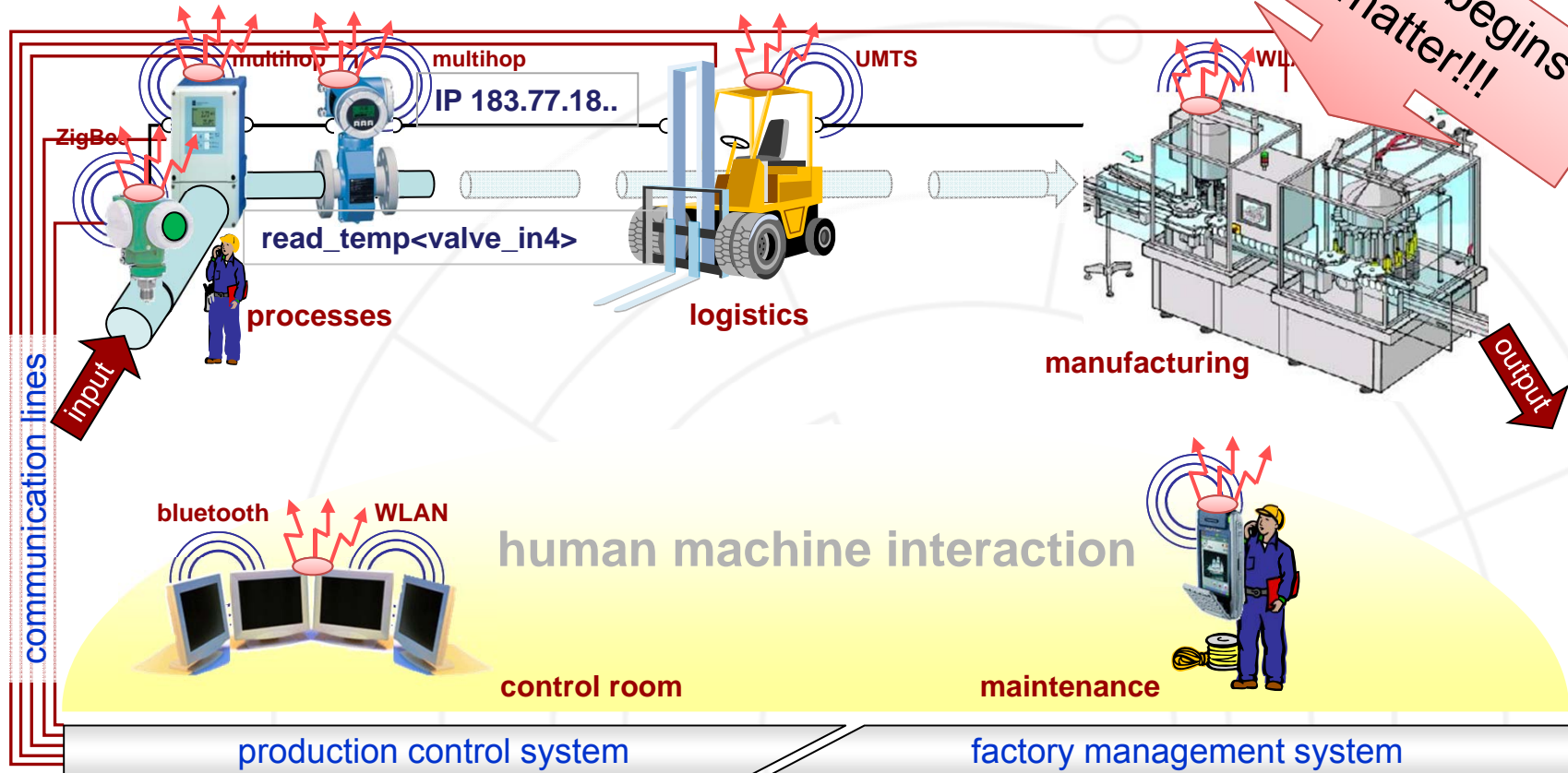

Everything is mobile and information will be available
anywhere, anytime, with any content, for any user
using any device and any access

In Factory Automation, Vertically Integrated Solutions are the Problem!

Successful examples for using RTLS within industrial applications are already existing, but...



Providers of location technology are focusing on monolithic applications



Solutions are engineered to fulfill highly specified and predefined tasks



Integration of alternative / additional location technologies into is complicated



Adaption of existing solutions to new application focuses is time-consuming

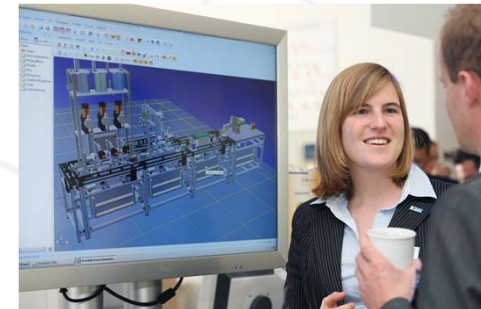

... today's integration solutions are lacking adaptability and flexibility in order to make them a real benefit for factory applications!

State of the Art

Architectural support for developing location and context aware applications is addressed in many research projects, but...

Schilit, B. N.: System Architecture for Context-Aware Mobile Computing. PhD Dissertation. Columbia University. 1995.

Brown, P. J.: The Stick-e Document: A framework for creating context-aware applications. In: *Proc. of the Electronic Publishing*. 1996. pp.259-272.

Dey, A. K.; Abowd, G.D.; Salber, D.: A conceptual Framework for and a toolkit for supporting the rapid prototyping of context-aware applications. In: *Human-Computer Interaction 2001*. 16(2). 97-166.

Bardram, J. E.: The Java Context Awareness Framework (JCAF) – A service infrastructure and programming framework for context aware applications. In: *Proc. of Pervasive 2005*. pp. 98-115.

Johanson, B.; Fox, A.: The Event Heap: A Coordination Infrastructure for Interactive Workspaces. In: *Proc. of the 4th IEEE Workshop Mobile Computer Systems and Applications*. IEEE Press. Piscataway. USA. 2002. pp. 83-93.

Bettini, C. u. a., 2010. A survey of context modelling and reasoning techniques. *Pervasive and Mobile Computing*, 6(2), 161 - 180.

Cappiello, C. u. a., 2006. Context Management for Adaptive Information Systems. *Electronic Notes in Theoretical Computer Science*, 146(1), 69-84.

Chen, H., Finin, T. & Joshi, A., 2004. Semantic web in the context broker architecture. Second IEEE Annual Conference on Pervasive Computing and Communications Proceedings : Orlando, Florida, March 14-17, 2004, 277–286.

Henricksen, K., 2003. A Framework for Context-Aware Pervasive Computing Applications. School of Information Technology and Electrical Engineering, The University of Queensland.

Roman, M. u. a., 2002. A Middleware Infrastructure for Active Spaces. *IEEE Pervasive Computing*, 1(4), 74-83.

Lucke, D.; Wieland, M.: Umfassendes Kontextdatenmodell der Smart Factory als Basis für kontextbezogene Workflow-Anwendungen. In: Roth, Jörg (Hrsg); Küpper, Axel (Hrsg); Linnhoff-Popien, Claudia (Hrsg): 4. GI/ITG KuVS Fachgespräch Ortsbezogene Anwendungen und Dienste", 2007.

... solutions often lack support for communication with automation technology devices or have not been evaluated in industrial application scenarios.

Use Case

Finding broken field devices in a plant infrastructure is not a trivial problem and very cost-intensive!

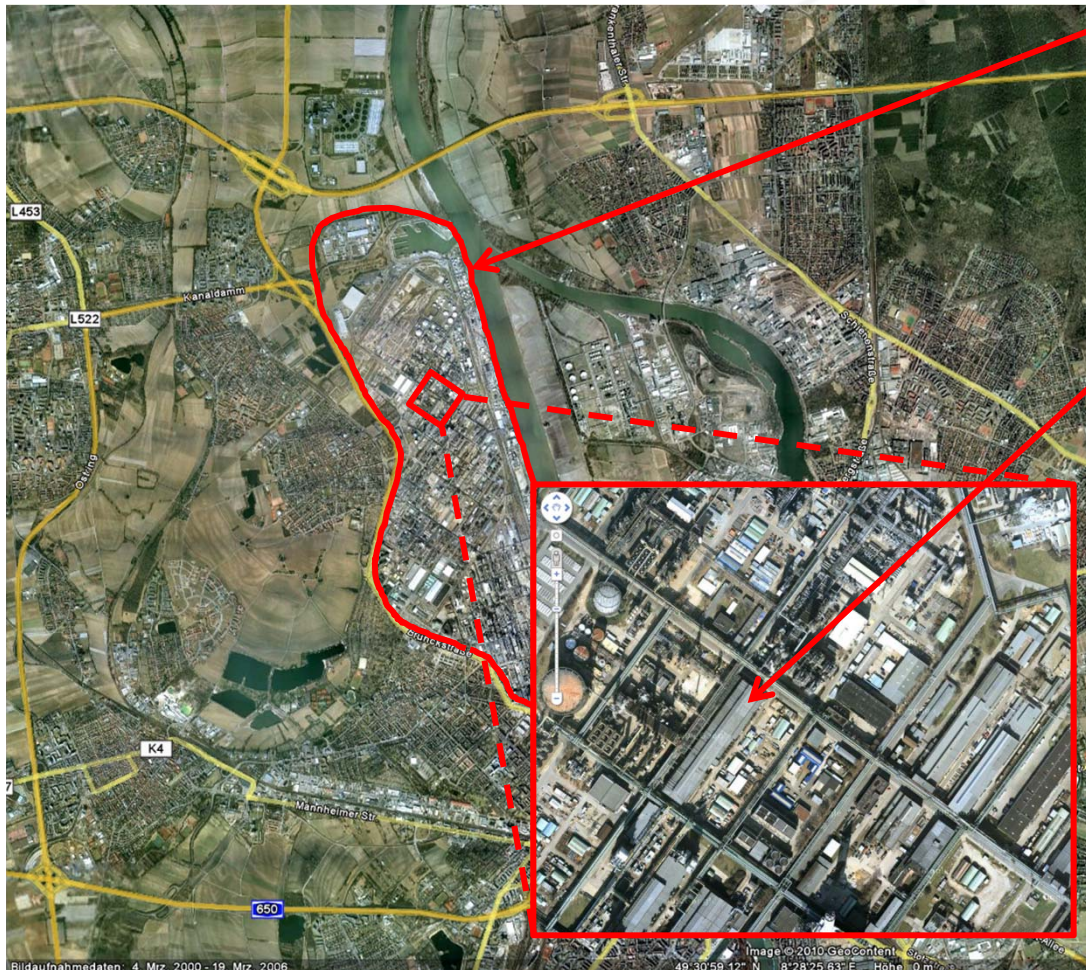

BASF AG, headquarter Ludwigshafen

- Area: approx. 10 km²
- No. of buildings: approx. 2000
- **Corresponds to ~ 1350 soccer fields!**

Typical field device:

- instruments / sensors
- Height: 0,4m
- Width: 0,2m



Exemplary calculation: Volkswagen AG, Wolfsburg

- Prod. units per day: approx. 5000
- Value per unit: approx. 20K€
- **Downtime losses: 70K€/min**

Test- and Demonstration Environment of the *SmartFactory*^{KL}

Living Lab represents a typical industrial production environment where prototype implementations can be evaluated.

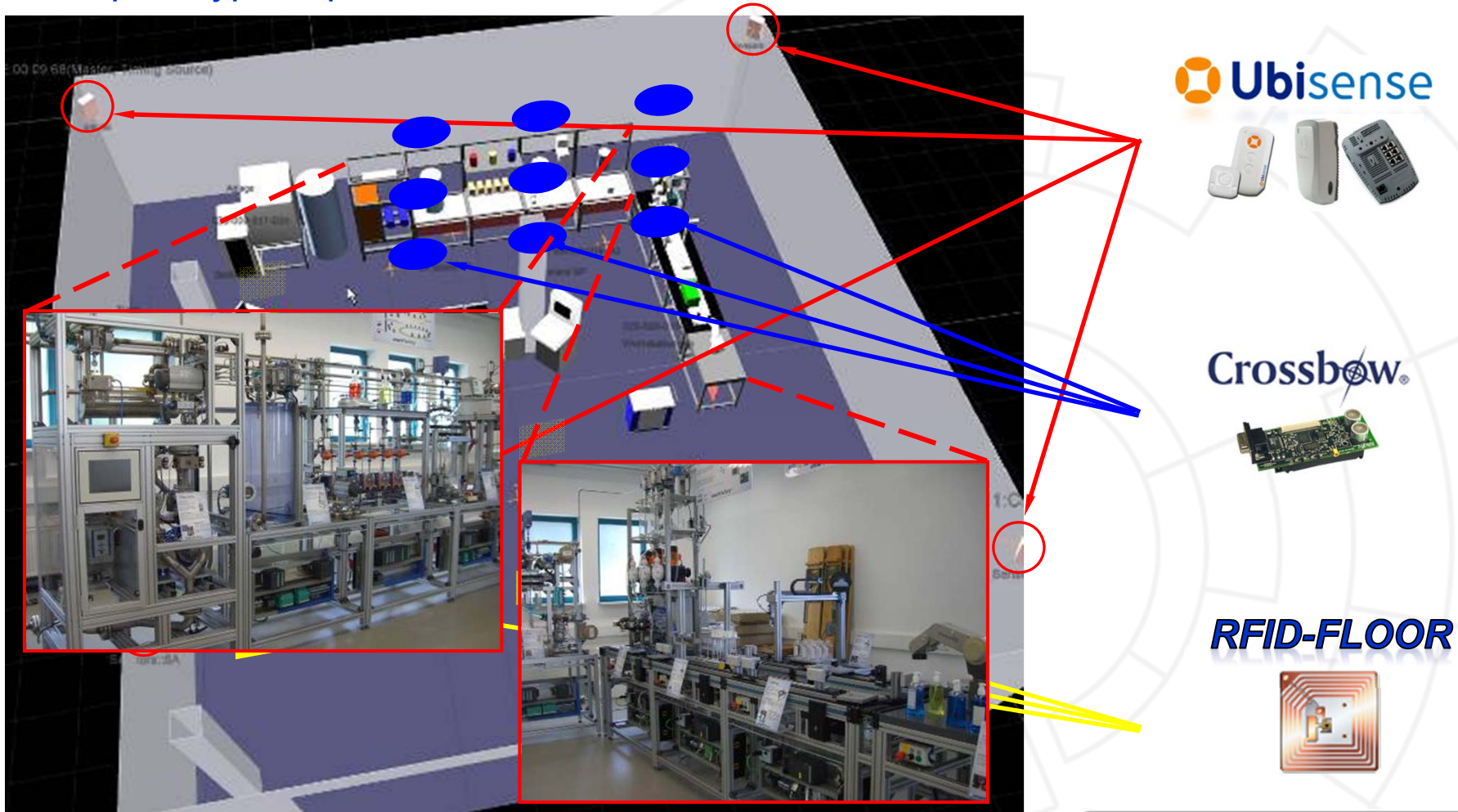

smartFactory^{KL}

Application scenario *SmartFactory*^{KL}

Prototype implementation of a navigation application to reduce search times in maintenance processes.

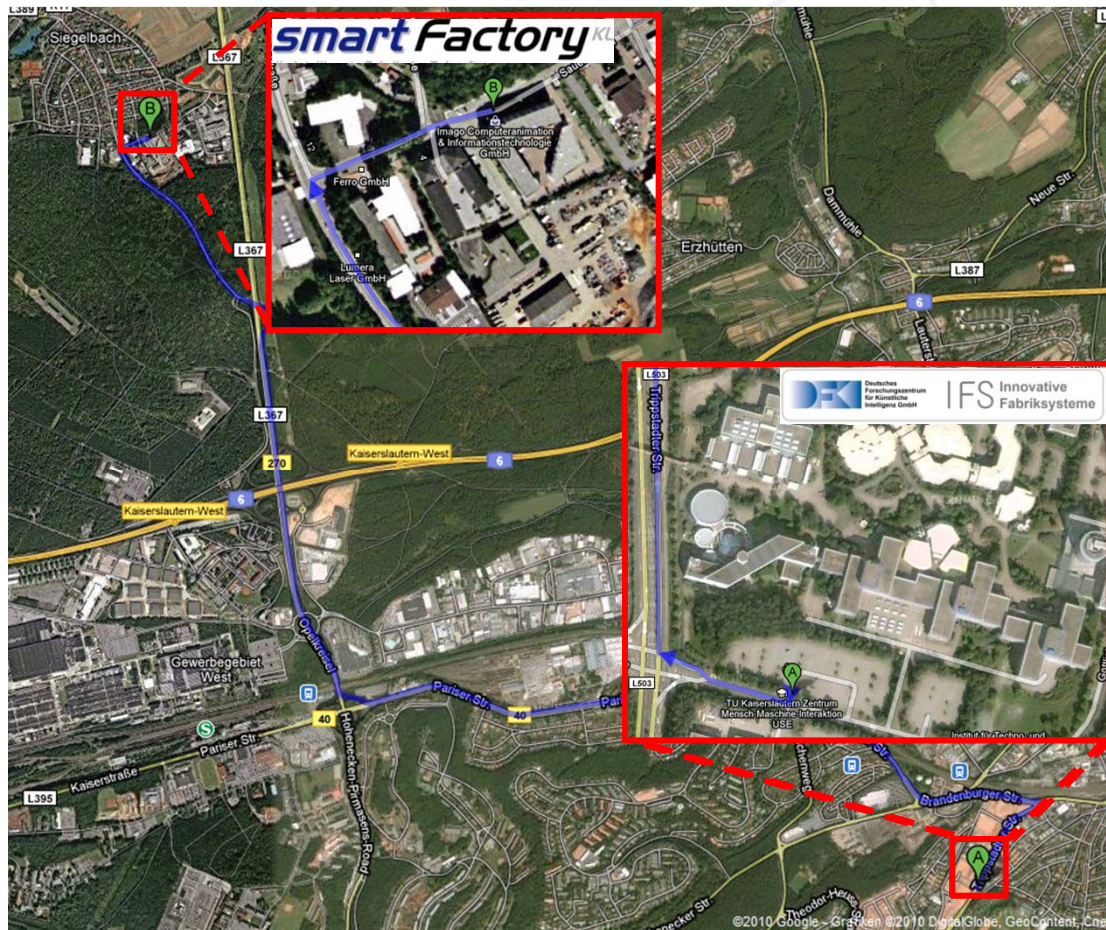

Development goals:

- Seamless navigation from outside the production plant to the location of a broken field device inside a building
- Linking incoming notification of a device breakdown with device location
- Provision of additional job-related information (detailed error description, data sheets)

Prototype Implementation

The existing solution allows a navigation from a location outside the production facility to a broken field device inside a factory building.

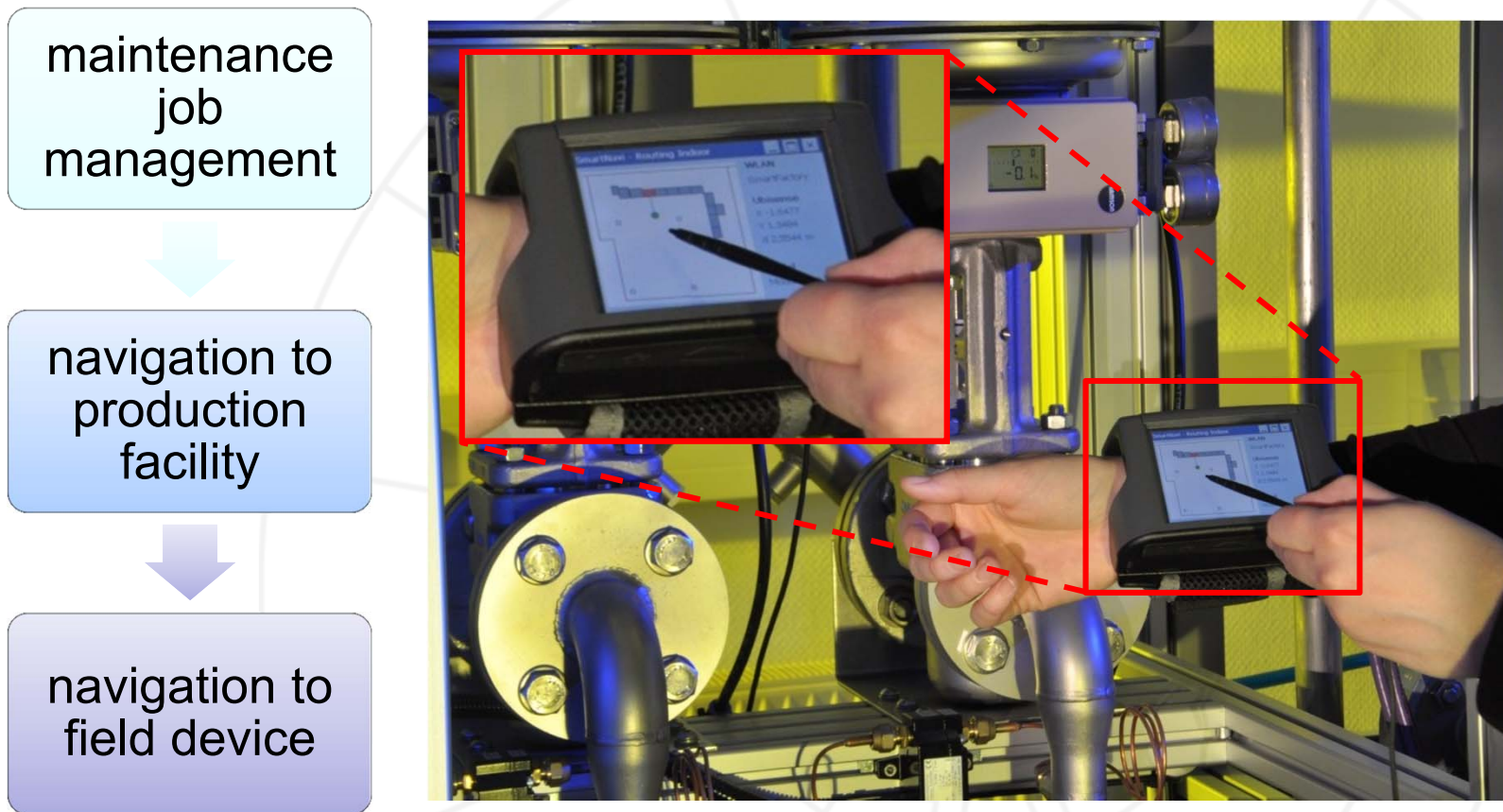

Stephan, P.; Heck, I.: Using Spatial Context Information for the Optimization of Manufacturing Processes in an Exemplary Maintenance Scenario. In: *Proc. of the 10th IFAC Workshop on Intelligent Manufacturing Systems. July 2010. Lisbon. Portugal.*

Research Challenges

To elevate the development of location-aware applications for industrial production to the next level, some research challenges need to be addressed.

Consistent data representation

Abstract representation of proprietary sensor readings as prerequisite for the easy integration of diverse location technology into factory systems and applications

Explicit knowledge representation and reasoning

Modeling of a formally represented knowledge encapsulating relevant rules and interrelations to interpret location raw data as prerequisite for dealing flexibly with location information in application contexts which are dynamically changing

Standardized information exchange

Communication via standardized interfaces and protocols as prerequisite for making location information and interpretation results easily accessible to various client applications

Architectural Approach

Goal: Implementation-independent representation of location raw data, maximum reusability of system components and strict separation of interpretation knowledge from application specific functionalities.

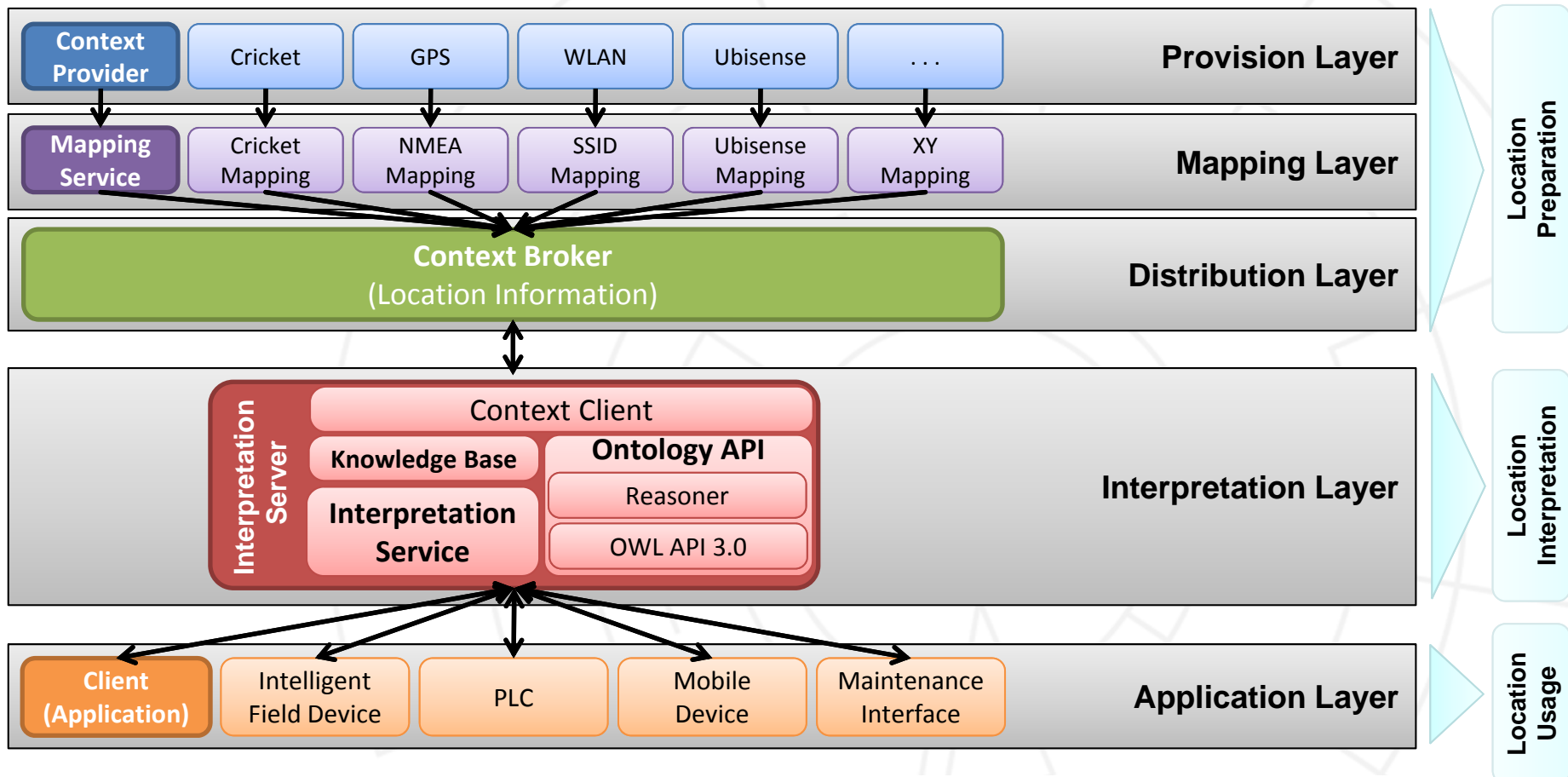

Data Representation

Use of ContextML in order to represent location raw data in a unified format independent from underlying technologies.

- Light-weight, markup-based scheme for representing context information and related meta data
- Proved its applicability and scalability in research projects (e.g. C-CAST) and was evaluated in the context of telecommunication applications
- Context information is defined as scopes comprising a set of closely related context parameters
- Parameters in one scope are always requested, updated, provided and stored at the same time

Knappmeyer, M., et al., ContextML - A Light-Weight Context Representation and Context Management Schema. IEEE International Symposium on Wireless Pervasive Computing, 2010.



But: ContextML does not provide a scope suitable for representation of comprehensive location information deriving from diverse systems.

Data Representation

Individually defined scope for location representation including absolute, symbolic and quality information.

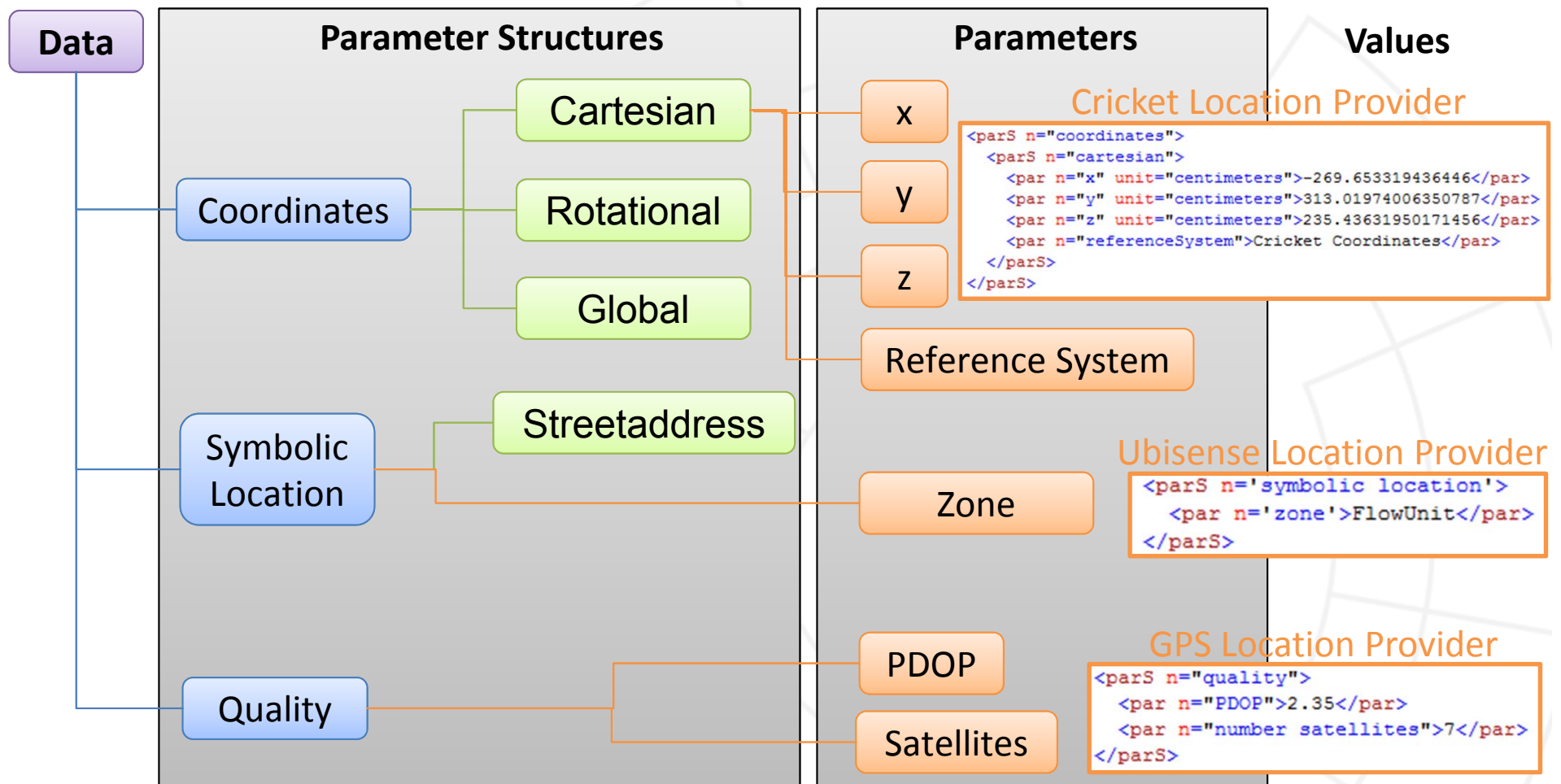

Data Interpretation

Use of ontologies in order to explicitly represent domain-specific knowledge and relevant rules to interpret location raw data.

- **Modeling language :** OWL DL
- **Ontology Editor:** Protégé
- **Reasoning Systems:** Pellet, FaCT++
- **Ontology querying:** Function library using OWL API 3.0
- **Ontology Content:** Classes, sub-classes & properties related to absolute location data and situation deduction
- **Goal:** Reliable deduction of navigation situation by reasoning about incoming location raw data

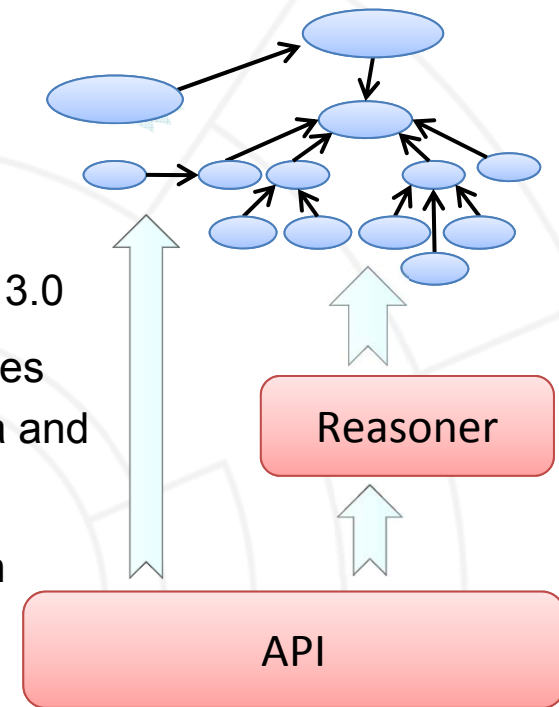

Comparably easy extension and adaption of knowledge base as prerequisite to deal with location information in application contexts which dynamically change.

Data Interpretation

Current state of work: Ontology to model different situations of a maintenance process is existing, reasoning systems Pellet and FaCT++ are under evaluation.

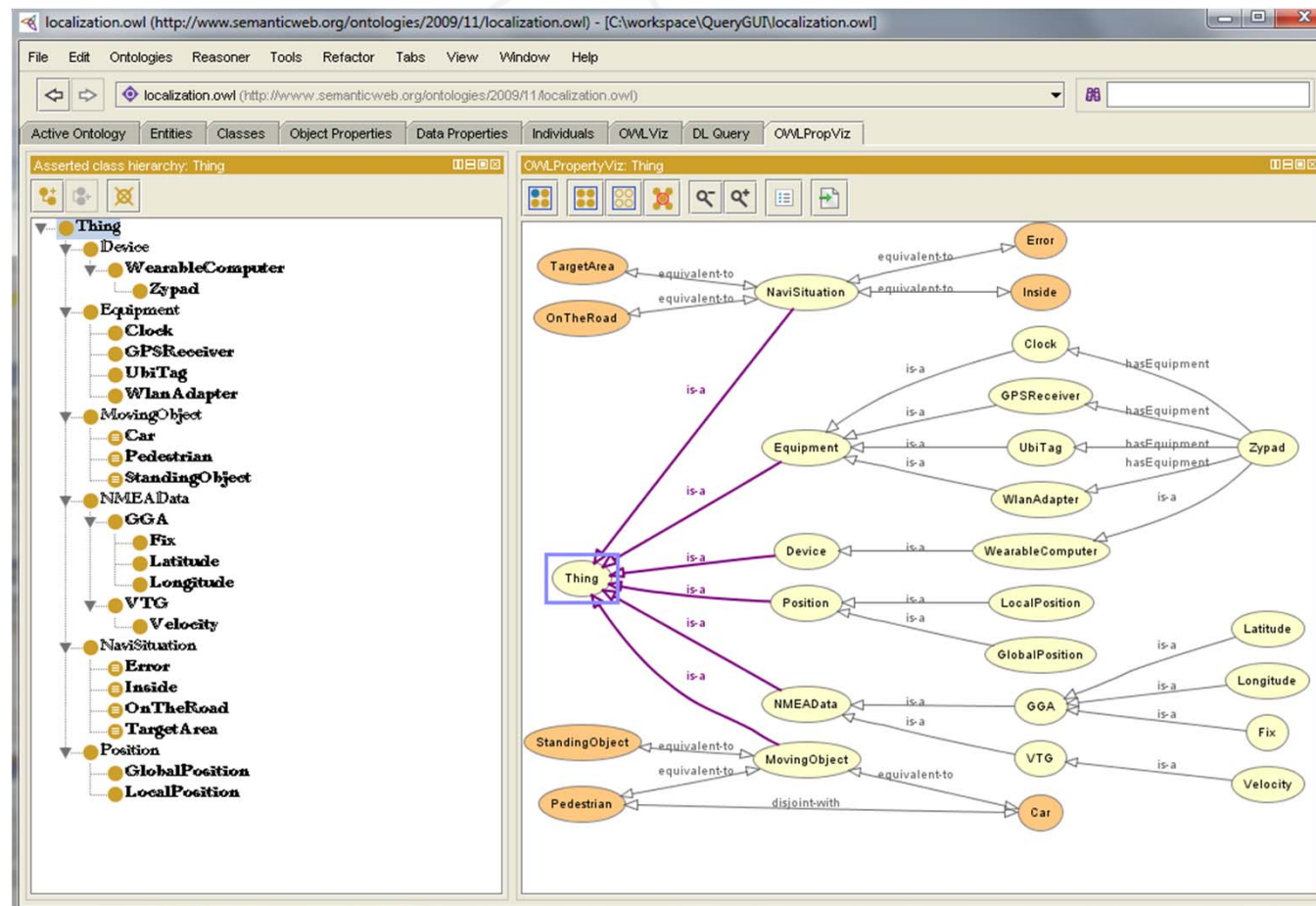

The Pyramid of Automation

yesterday

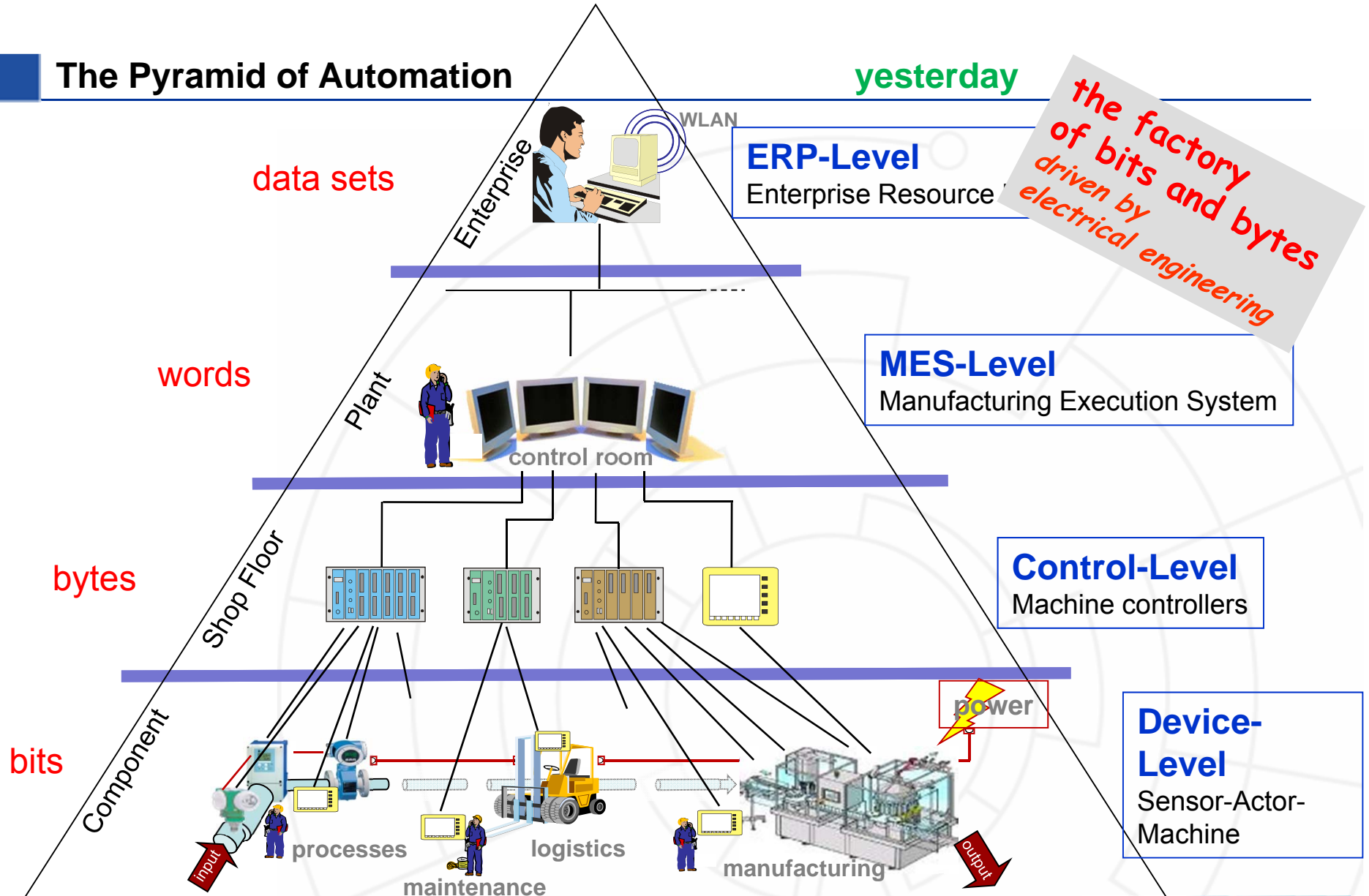

The Pyramid of Automation

today

To services

Via functions

Via data

From signals

the factory of functions driven by software engineering

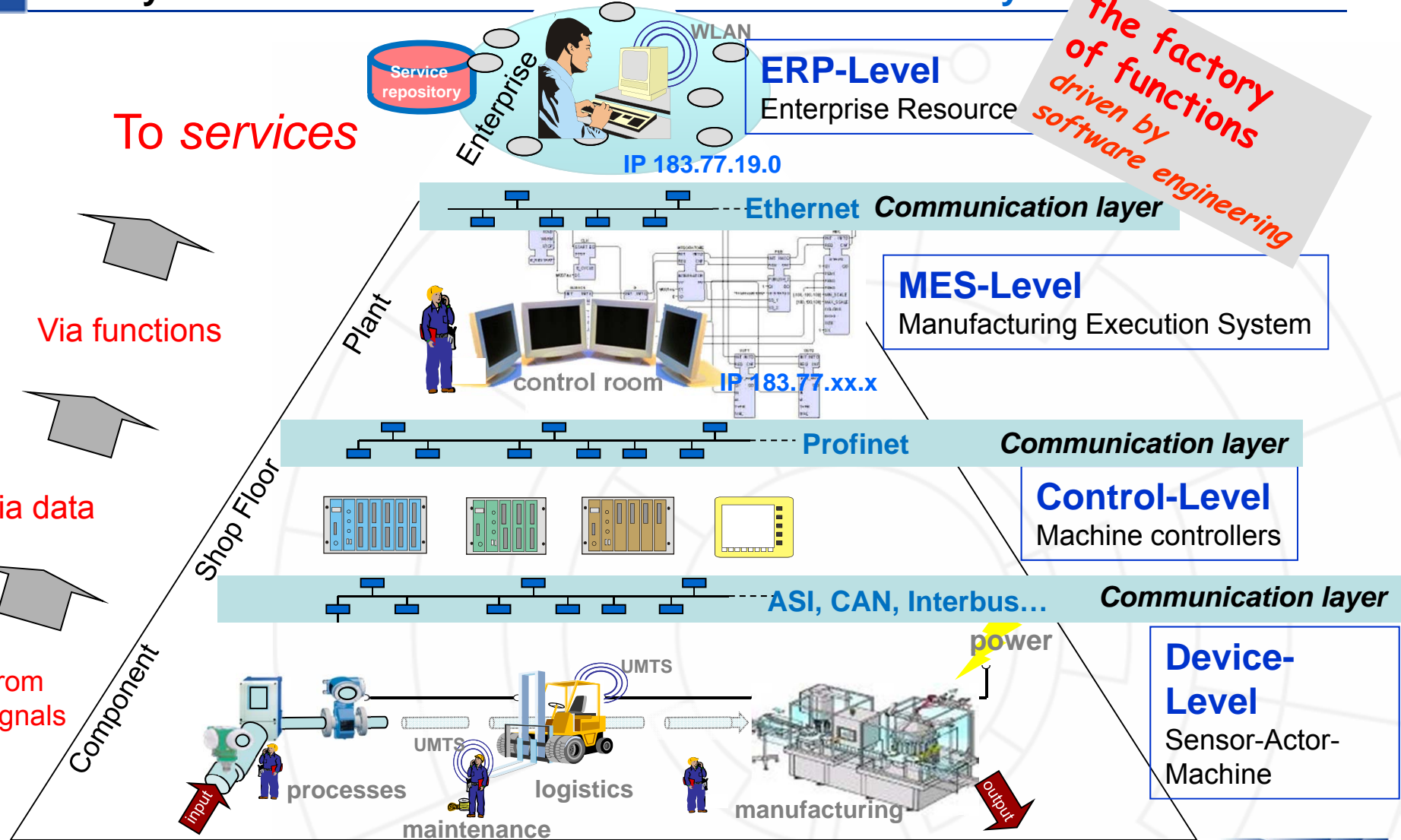

The Pyramid Network of Automation Services

tomorrow

from services

to services

the factory of things driven by artificial intelligence

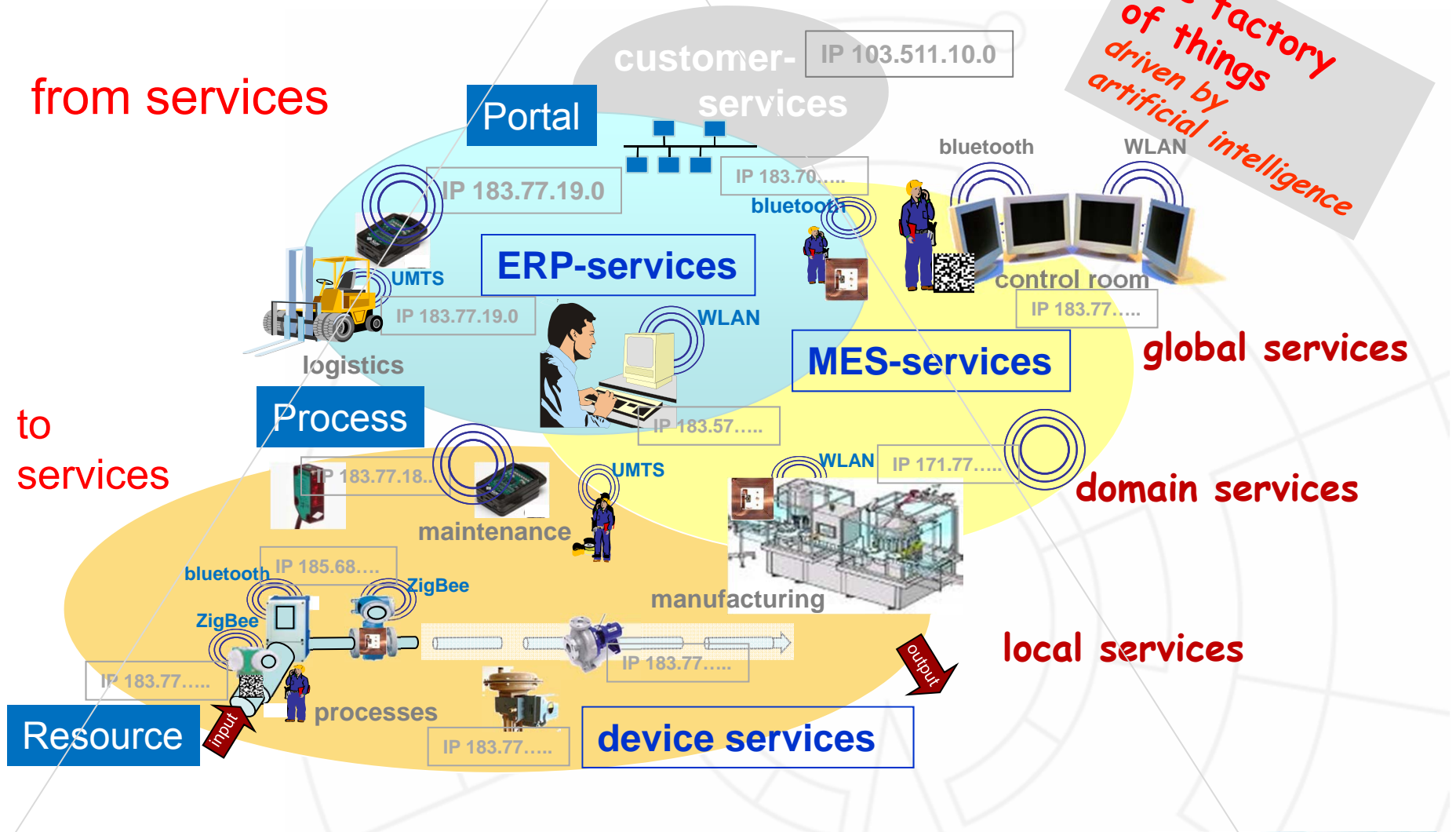

REST Style Architecture for Communication

Properties that the REST style architecture propagates support the principles of the factory of things.

Adressability

Every resource in the real world is adressable by a URI making factory objects and field devices identifiable and accessible over the web

Statelessness

Requests to resources happen in in isolation and are independent from each other, fostering their use also on lightweight automation systems

Links and Conectedness

Resources can be interlinked with each other and with information from the web supporting the use semantic technologies in a factory of things

Uniform Interface

For every resource only a limited set of methods is defined and the result of applying them is known already in advance allowing the easy composition of automation data and services

Benefits and Limitations

In future factories, where data can be accessed from everywhere, at any time by any device, location information is supposed to be a key to a situation specific information management.

Architectural Benefits

- Will offer a future-proof basis in dealing with technological diversity and supports a flexible adaptation of application and domain specific interpretation knowledge
- Allows for the provision of situation and task specific data to users and technical systems based on location information
- Will follow established Lean-paradigms in designing industrial IT- and manufacturing systems

Crucial Issues

- On the technical side: Scalability; how many location aware client applications which can be supported this way
- On the user side: Privacy; acceptance will finally decide about success or failure of location-aware applications in every-day industrial use

Outlook

Conduction of performance test, extension of existing ontology, inclusion of Semantic Web Rule Language.

- **Performance Testing:**
Determination of processing time for web service invocation and ontology querying within the architecture
- **Ontology Extension:**
Inclusion of symbolic location information into ontology to allow for a more fine grained and reliable situation determination
- **Inclusion of SWRL Rules:**
Enrichment of ontology by SWRL rules for reducing the complexity of logical expressions to reason about a prevailing situation



Benefits of spatial context information in the maintenance domain

Spatial context information as a key to optimize maintenance processes and to a higher availability of production plants.

- Transparency increase by recording of spatial context information and their analysis allows the assessment and optimization of **process quality**
- Use of spatial context information speeds up maintenance processes by decreasing **search times**
- Savings in time in maintenance processes leads to higher **availability** and overall equipment effectiveness (OEE)

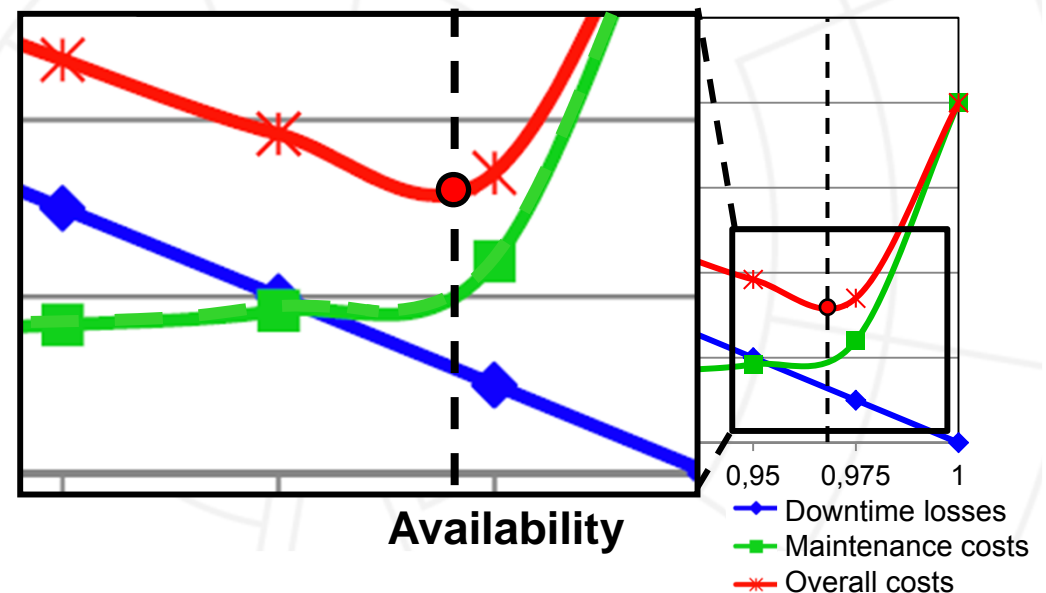
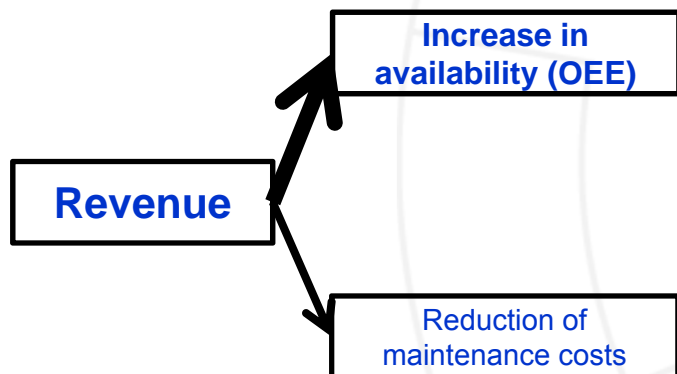



Thank you for your attention!